

# I'DGO TOO and Visions2030

## The University of Salford

Presented by Rita Newton and Marcus Ormerod

The built environment

– yesterday, today, tomorrow?

# The built environment - yesterday



University of Salford



University of Salford



University of Salford

# The built environment - today



University of Salford



University of Salford

# I'DGO Detailed Design Research

What are the key attributes of detailed design (at both the street scale and neighbourhood scale) likely to influence aspects of older people's quality of life?

Method – in-depth interviews with 200 older people; physical audit survey of the street, and neighbourhood in which these older people live

# Example 1 Footways:

## Wide and flat tarmac footways



- Can avoid street furniture and pedestrians
- Feel safe from traffic
- Tarmac seen as smooth, even, non slippery, safer from tripping, comfortable to walk on
- Should be well maintained
- Need distinguished path for cyclists

# Example 2 Seating: Frequent, warm, supportive seating, well maintained and safe



# Example 3: Bus stops and shelters



- Provision
- Weather protection
- Seating
- Personal safety
- Seeing the bus



# Tactile Paving...



## Department for Transport Guidelines

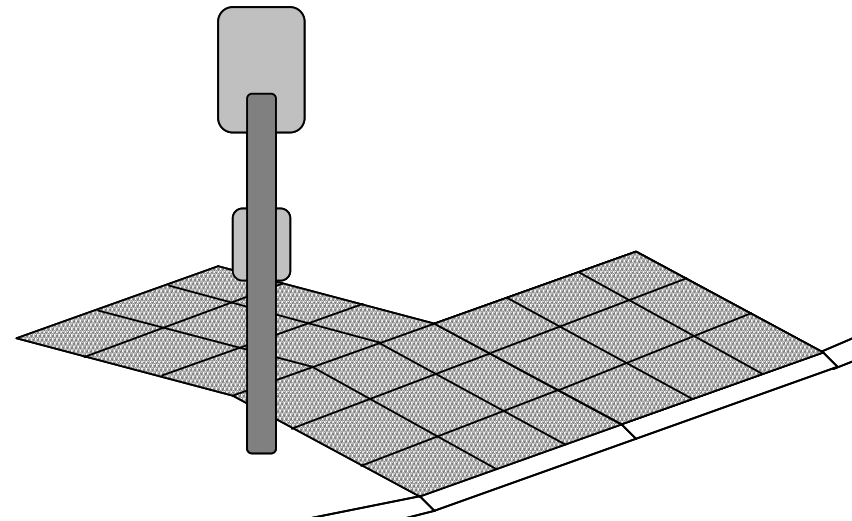

“feels as if you are going to twist your ankle on it”

“makes me feel unsafe, I feel I might trip & it hurts my feet”

“I prefer to walk around it”

## **Objectives of the I'DGO study: (tactile paving as an indicator of hazards)**

- **To examine how blister and corduroy tactile paving is designed, sited and laid.**
- **To identify older people's perceptions and approach to using tactile paving.**
- **To quantify the relationship between tactile paving design parameters and the biomechanics of ambulation and risk of falling.**



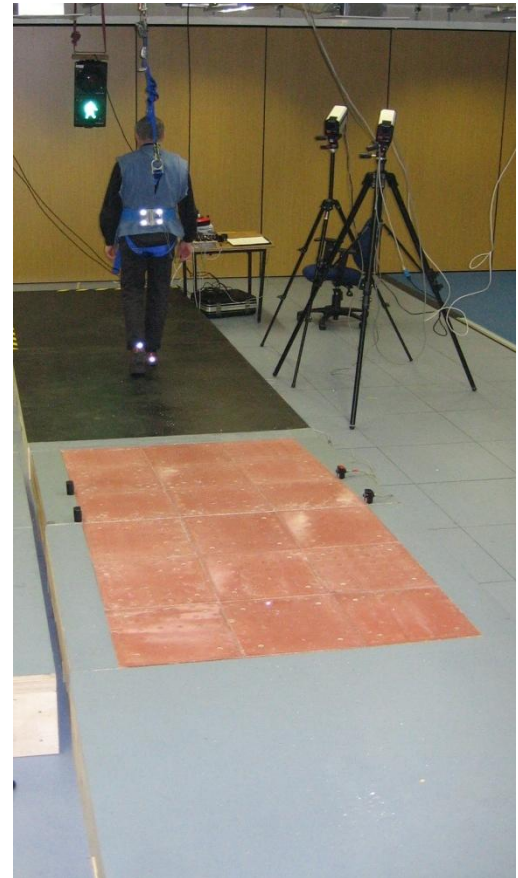
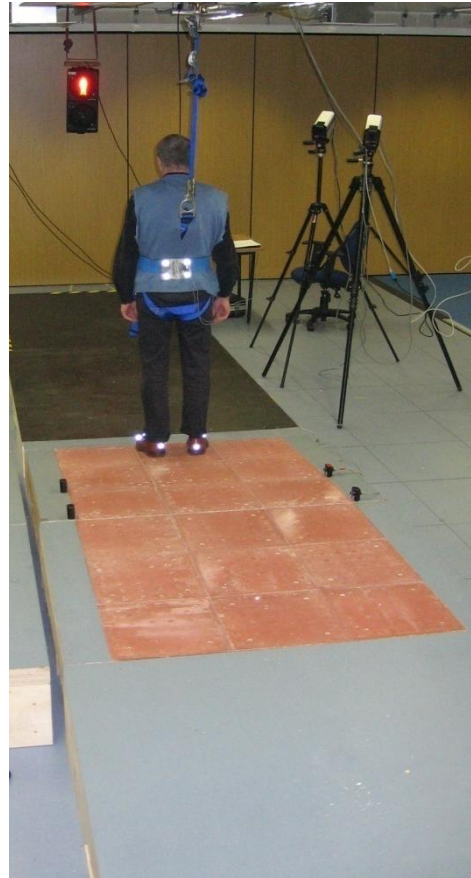

# Experimental Work: Methods



- ❑ 32 older participants (mean age 72 years)
- ❑ Two surface conditions:
  - ❑ Smooth grey granite
  - ❑ Red blister pavement
- ❑ Three walking conditions:
  - ❑ Continuous walking with light on “green”
  - ❑ Walk, stop, wait & start with early “red-trigger”
  - ❑ Walk, stop, wait & start with late “red-trigger”
- ❑ Reflective markers on shoes and waist for calculation of gait parameters

# The built environment – tomorrow?

# Visions for the role of walking and cycling in 2030

**Partners:** Universities of East Anglia, Leeds, Manchester, Oxford, Salford, plus a range of non academic partners

# Aims of Visions 2030

---

Help create a better walking/cycling / public transport future in the UK

Identify socially-, environmentally- and economically-desirable urban futures where walking and cycling play a substantially enhanced role in society

Identify feasible pathways as to how these futures might be realised





Victorian Street (2009)



60/70s estate (2009)



**Vision One (2030)**



Vision Two (2030)



MH

Hub 150m



Vision Three (2030)